

Arduino Based Real Time Health Monitoring System for Telemedicine Services of Bangladesh

Uzzal Kumar Prodhana*¹, Mohammad Zahidur Rahman² and Israt Jahan²

¹PhD Researcher, Department of Computer Science and Engineering, Jahangirnagar University & Department of Computer Science and Engineering, Jatiya Kabi Kazi Nazrul Islam University, Trishal, Mymensingh, Bangladesh

²Department of Computer Science and Engineering, Jahangirnagar University, Savar, Dhaka, Bangladesh

Abstract

In this research, we have developed a real time health monitoring system for the people of Bangladesh. We have implemented this system with arduino uno, android mobile and an interoperable health system for delivering the health services to the rural people of Bangladesh. Real time health monitoring system reduces the risk of patients. We have collected the remote rural patient's vital information through our developed portable telemedicine tool kit in real time and this data are then transmitted to the health system of the telemedicine model. We are using a low cost height and weight sensor to get the rural patients information remotely. By using our developed system, expert doctor can easily find the history of the patients and test patients remotely with the help from the local doctors. The remote rural patients will get the telemedicine services from the expert doctors. Finally, we can say that our implemented monitoring system is cost effective, sustainable and easily maintainable for the treatment of the people of Bangladesh.

Keywords: electronic health record, wireless body area network, electrocardiogram, health level seven, business process diagram, business process modeling notation

Introduction

The developing countries suffer inadequate healthcare and medical services. Lack of health care professionals and infrastructure contribute to this problem making it more and more difficult to deliver health care to people in rural and remote communities of the developing world [1]. Over the past few years, there has been a growing interest in ubiquitous health monitoring [2]. Specialist healthcare service availability is a huge challenge facing the developing countries of the world like Bangladesh. Qualities of healthcare services in urban and rural areas are not evenly distributed. This is owing to inadequate physicians in rural areas healthcare

*E-mail of correspondence: uzzal_bagerhat@yahoo.com

services [3]. In Bangladesh, number of doctors per 10000 populations is 1.43 [4]. Physician population density among Western Pacific region and Bangladesh is shown in figure 1. From figure 1, we can see that Bangladesh is the second lowest among the regions [5]. People living in rural areas of Bangladesh don't have access to quality medical facilities. Hence, we need to develop a real time healthcare system that removes the geographical barriers and improves the doctor to patient ratio virtually so that healthcare facilities are available to remote areas of Bangladesh easily [6].

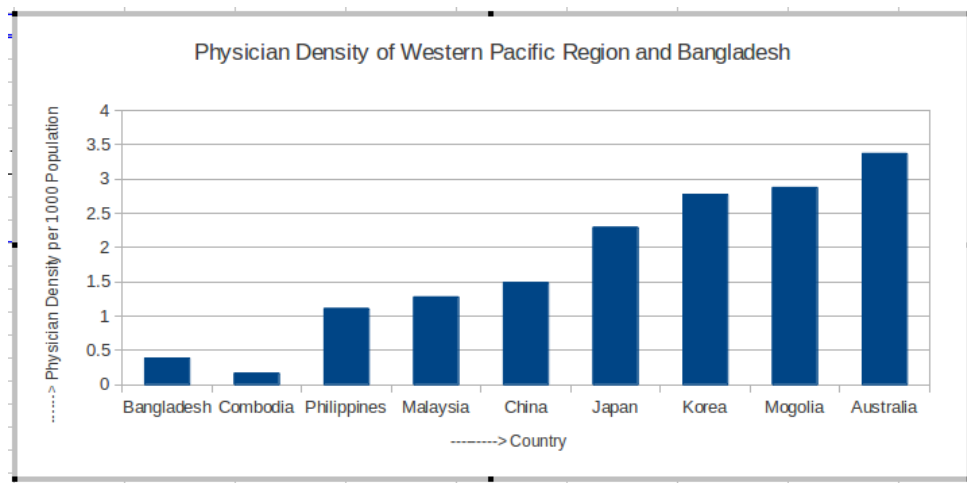

Figure 1: Physician-Population ratio of Bangladesh and Western Pacific region [5]

Telemedicine offers a solution to the challenges of accessing effective and timely healthcare, especially among rural people of Bangladesh where lack of availability of expert doctor. Recent survey showed that 92.42% patients and 94.80% expert doctors want to introduce telemedicine services for the poor people of Bangladesh [7]. From the survey published in 2017, we came to know that most of the expert doctors of Bangladesh respond on real time mobile based patient management system for the telemedicine services [8]. A telemedicine model will be sustainable and affordable if it is inter-operable with the health system [9]. Considering the above situation, we are going to develop a real time patient monitoring system to be used in telemedicine services of Bangladesh.

The rest of the paper is organized as follows: In section 2, recent literatures are reviewed with a view to know the present states of the research and the scopes of further research. In section 3, proposed model is explained with its processes. Section 4 elaborates the methodologies of the proposed research. Section 5 lists the key results. Section 6 discusses about the research and major advantages of the proposed research. Section 7 concludes the research.

Review of Literature

Relevant current researches are analyzed in this section to find out the recent development of telemedicine services. Researches on real time health monitoring system are also critically reviewed to make the proposed system cost effective.

Telemedicine approach for remote patient monitoring system was developed by Syed Thouheed Ahmed and others in 2016. In this research, they have developed cost efficient hardware for remote patient monitoring with smart phone. They have reduced the hardware cost for the rural people. They will include more sensors to make the system more effective for the patients [10].

In 2015, telemedicine centers were implemented by the researchers Imran Bin Jafar and others in South Asian countries. In this research, authors developed a remote diagnostic center with four sensors like ECG, blood pressure, SPO2 and temperature and a micro-controller. Patients and doctors can be connected with the center through Internet. This model is not inter-operable with other health system [11].

Application of Electronic Health Record (EHR) system for human disease prediction was done by Mohammad Kamrul Alam Sikder and others in 2013. Authors have designed a faster and secured EHR system which has different functionality for users [12].

Ananda Mohon Ghosh and others demonstrated a health care system for hospital management. Through their developed system, they allow guardians along with doctors to remotely monitor health conditions of patients via Internet in an authenticate manner. The system collects data

from patients and stores the gathered data into cloud for permanent use that can help health professionals to remotely health monitoring [13].

Authors propose a novel health care communication architecture which will connect remote telemedicine nodes with remote doctors in specialty hospitals in 2016. They have tested this system over 60 nodes in India for cardiac patients [14].

Wireless health monitoring using passive WiFi sensing is developed by Usman Mahmood Khan and others in 2017. Authors showed that passive WiFi systems show great promise in replacing typical invasive health devices as standard tools for health care [15].

Authors setup a virtual hospital with limited resources for real time patient monitoring based on wireless body area network in 2016. They have used knapsack cryptographic algorithm for encrypting the patient data and remote doctors can access the data for the treatment of the patients [16].

In 2016, authors worked on secure and wearable computing in wireless body area networks (WBANs). Authors provide a secure transmission channel for information to go through. In this research, authors are employing an encryption key technique and the biometric sensor technology to make the transmission channel secure [17].

Proposed Telemedicine Model

In this research, we propose a telemedicine model which will be implemented in hospital or a health organization and it can be accessed remotely by any authorized health professionals. Our telemedicine model is based on a Health Level Seven International (HL7) certified health system. This health system is inter-operable with the other HL7 based health system. So, this model will be accepted in Bangladesh and all over the world. We can overcome the difficulties of the present telemedicine models in our country through our model. Data interoperability problem among the healthcare organizations will also be removed and doctors can easily deliver their treatment to the rural people. There are four processes in the proposed model. These are remote healthcare management process, local doctor process, expert doctor process and health lab technician process. Remote doctors and expert doctors will log-in to the health system through

a customized developed module. The activity of the processes is shown in the Business Process Diagram (BPD). BPD diagram 2 is demonstrated through Business Process Modeling Notation (BPMN). We have used Camanda Modeler tool to represent the BPD diagram.

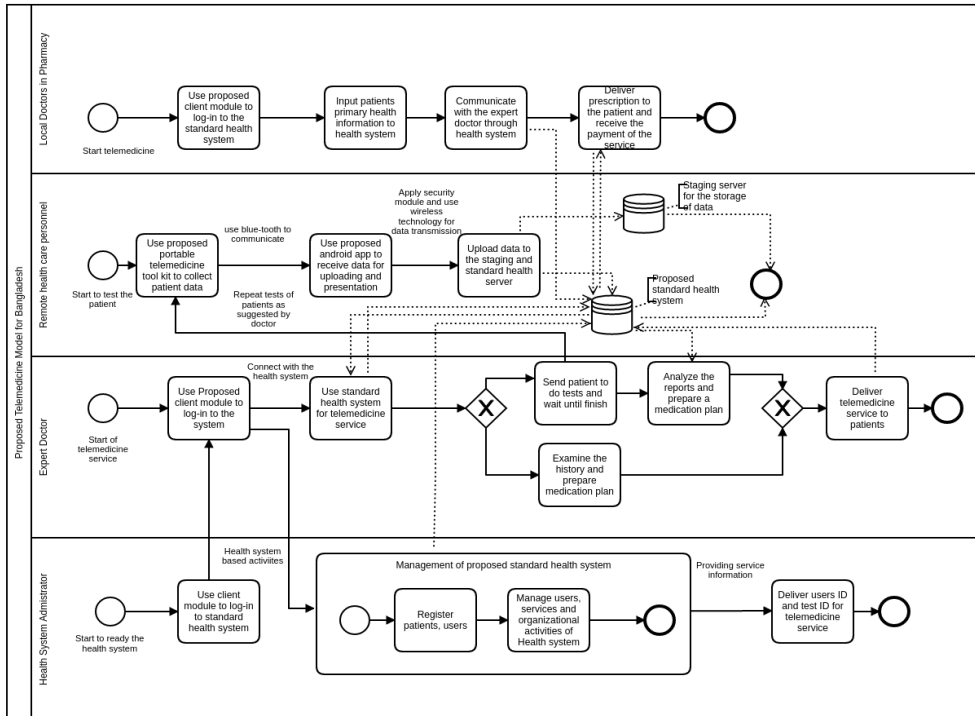

Figure 2: BPD diagram of proposed telemedicine model

Methodology of the Research

In order to complete the proposed research, we have analyzed the present real time health monitoring system used in Bangladesh and abroad. We have found the scopes of implementation of this system in telemedicine model. The methodology of the research is given below:

Development of health system for telemedicine service

Proposed telemedicine model is shown in figure 2. This model is based on Pool and Lane of BPMN. This model is easily understandable by business analysts who create and refine the processes, the technical developers who

implement them, and the business managers who monitor and manage them. This model uses HL7 based health system which is sharable and accessible from the remote locations by healthcare professionals. We have used an open source health system GNU health as a health system for it's widely used in developing countries. We have implemented this interoperable health system in a server and telemedicine services are given to the remote rural people through this system. Figure 3 shows the remote doctor log-in window from the pharmacy of a local village. The management of the system and users are maintained by the admin of the developed system.

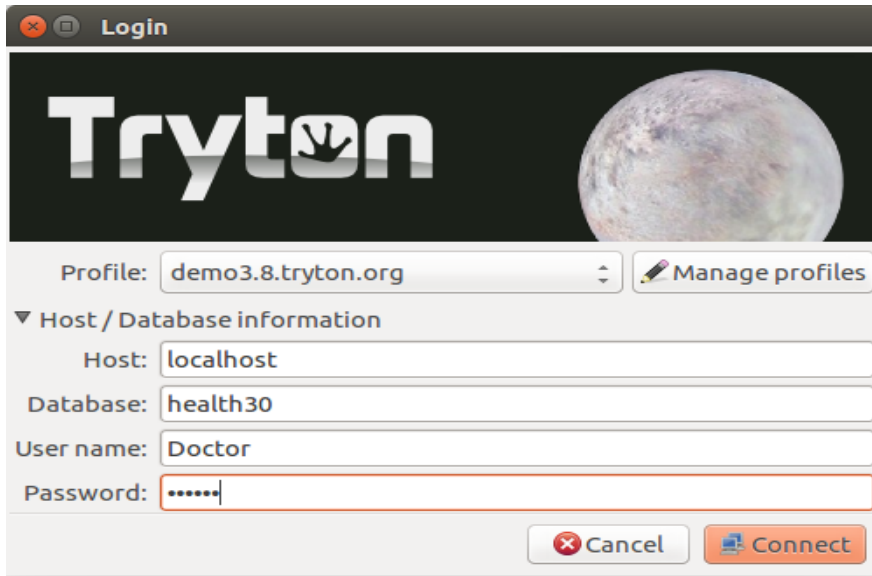

Figure 3: Remote doctor log-in window

Development of the components of the model

The main components of this model are developed portable telemedicine tool kit, client log-in module height sensor, weight sensor, android app, staging server and health system. In this research, we have developed the height sensor to measure the height of patients. The hardware organization of the height sensor is shown in figure 4. Currently, arduino is used in a variety of application areas for its low cost and easily interface with other devices. We have used arduino to calculate the height and weight of

patients. In the case of height sensor, we have used ultrasonic sensor to measure the height of patients.

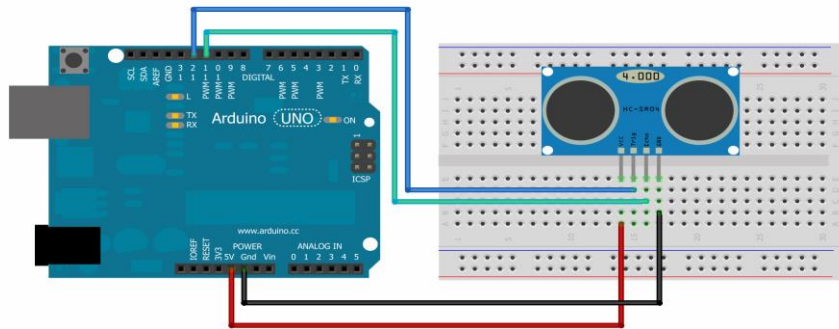

Figure 4: Hardware organization of Height Sensor

The hardware organization of the weight sensor is shown in figure 5. The components of the weight sensor are arduino uno, hx711 amplifier and a load cell. We have used a load cell of 250 kg to measure the weight of patients. Load cell senses the load in voltages and it is amplified by the HX711 amplifier. The amplifier transfers the voltage differences to the arduino uno. We have uploaded the code to the arduino and made weight adjustment for displaying the accurate measurement in real time through mobile app.

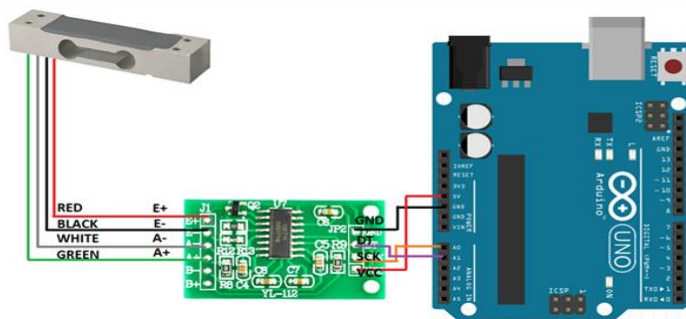

Figure 5: Hardware organization of Weight Sensor

The component diagram of our developed portable tool kit is shown in figure 6. This research has developed a cost effective portable tool kit to

collect the vital signs of patients. This device is Blue tooth enabled. We can easily connect our developed sensors to the kit and test the patients. Real time test data are then available through the developed android app.

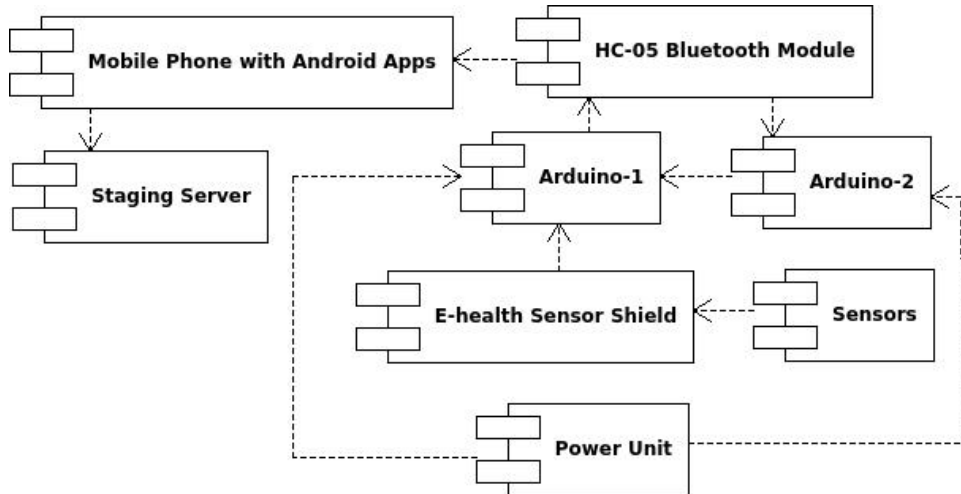

Figure 6: Portable telemedicine tool kit component diagram

In order to connect with the health system of the proposed telemedicine model, we have developed the client log-in module. The component diagram of the client log-in module is shown in figure 7. Internet connection and this module is used to connect to the health system for the delivery of telemedicine services.

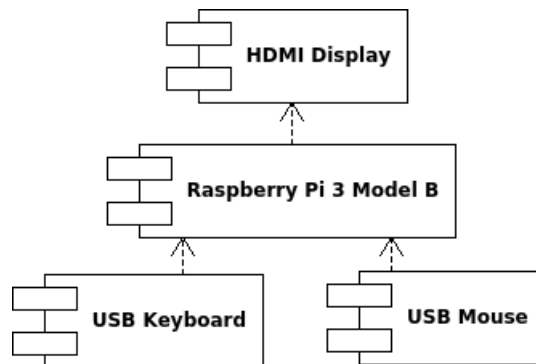

Figure 7: Component diagram of client log-in module

The deployment diagram of the telemedicine model is shown in the figure 8. From the model, we can see the overall arrangements of the system. Remote local doctors and trained healthcare professionals are equipped with the remote telemedicine device as shown in figure 8.

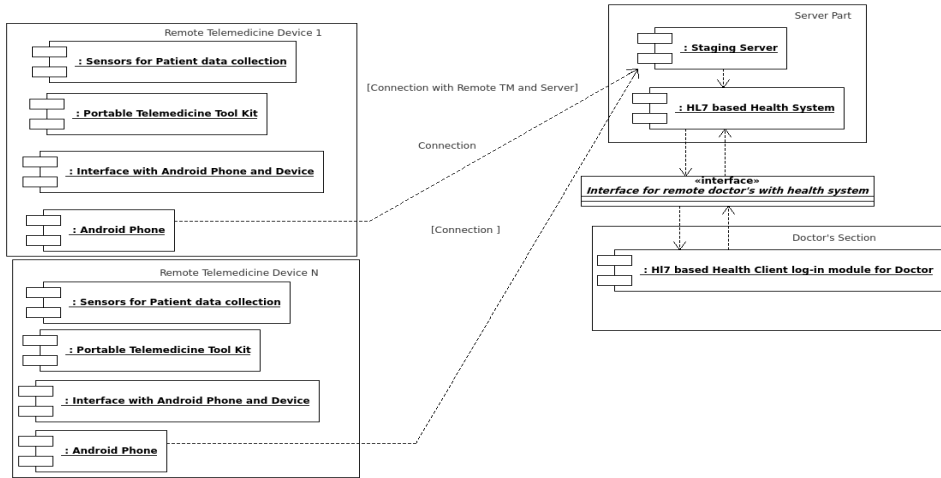
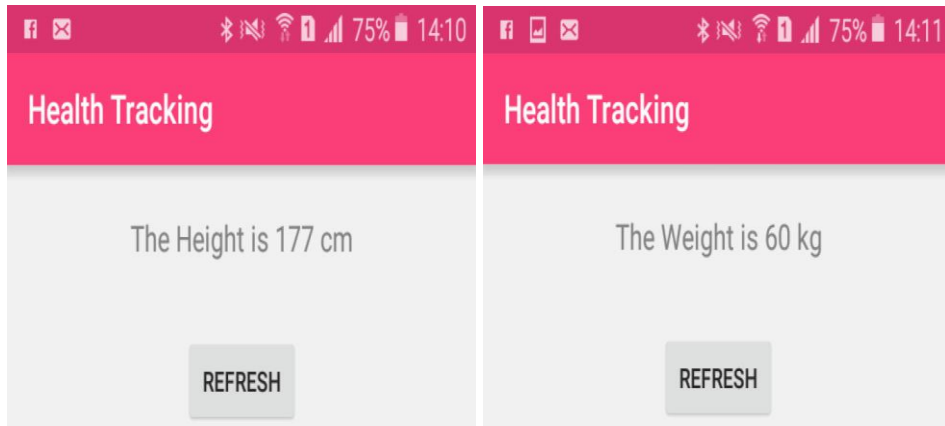

Figure 8: Deployment diagram of proposed telemedicine model

We have developed an android app called “Health Tracking” for real time visualization of test data of remote patients. We have used Bluetooth with the telemedicine tool kit and used a password based pairing of Bluetooth devices for providing more security of the system.

Experimental Results

We have developed all the components as shown in figure 8. In the portable telemedicine tool kit we are currently using two sensors to use in telemedicine services. In this case, we are using height and weight sensor. We have developed the hardware's in the telemedicine lab of Jahangirnagar University. We are getting the accurate data from the sensors. We have used our developed android app to collect the remote patient’s data from the tool kit. After visualization of the data from patients in real time, we can upload the data to the staging server. Staging server is used as separate components for storing the history of patient data. We then run a python script to sink the data from the server to the health system. Figure 9 shows the height and weight sensor data from remote patient in real time through the app.



(a) Data from Height Sensor

(b) Data from Weight Sensor

Figure 9: Real time data from height and weight sensor

The sensors list that will be used with our portable telemedicine tool kit and store the test data in the staging server are shown in the figure 10.

#	Sensor type id	Sensors	Actions
6	1	BLOOD PRESSURE	Update
7	2	SENSOR ECG	Update
8	3	SPO	Update
9	4	AIR FLOW	Update
10	5	BODY POSITION	Update
11	6	GL METER	Update
12	7	TEMPERATURE	Update
13	8	Height	Update
14	9	Weight	Update

Figure 10: Sensor list of patient's test data in staging server

A patient will have to register into the health system to get the service by the health system administrator. After registration, the local doctor will input the history of the patient to the health system. Expert doctor will examine the details of the patients and advice tests of the patients. The patients are then tested with the tool kit and real time visualization of data

through the app. When the test data are available in the staging server, we run the python script to get data from the server to the health system. Figure 11 shows the history of the patient data inserted by local doctor.

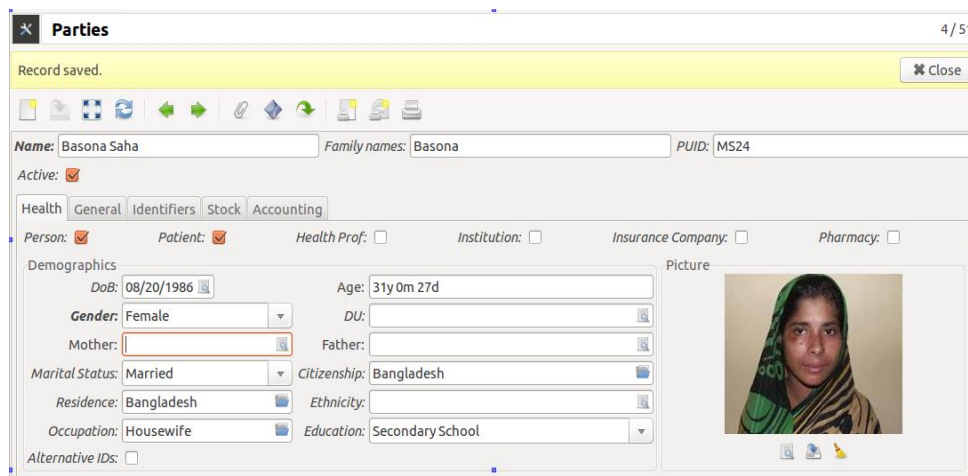

Figure 11: History of patient from health system

Figure 12 shows the lab test requests of patients from the health system for telemedicine services. Lab test results are found from the health system after the field test of the patient. Figure 13 shows the lab test results of rural patients. Prescription is prepared by the expert doctor after examining all the related history of patients. Local doctor will print the prescription and deliver to the patient.

Request	Test Type	Date	Date	Patient	Doctor	State
49	Height	09/23/2017	15:12:12	Succi Akter	testdoc	Draft
48	Height	09/23/2017	15:11:36	Popy Siddique	Tutul Bhattachryya	Draft
47	Weight	09/23/2017	15:11:00	Sreya	Tutul Bhattachryya	Draft
46	Weight	09/23/2017	15:04:35	Rahim	Tutul Bhattachryya	Draft
45	Airflow	08/01/2017	14:38:52	Nadira akter	Tutul Bhattachryya	Ordered
44	Airflow	08/01/2017	14:37:47	Popy Siddique	Tutul Bhattachryya	Ordered
43	Airflow	08/01/2017	14:37:26	Umme Salma	Tutul Bhattachryya	Ordered
42	Airflow	08/01/2017	14:36:55	Rokeya Khatun	Tutul Bhattachryya	Ordered
41	SPO2	08/01/2017	14:29:17	Maya, Khondoker Maya	Tutul Bhattachryya	Ordered
40	SPO2	08/01/2017	14:28:48	Maya, Khondoker Maya	Tutul Bhattachryya	Ordered

Figure 12: Lab test request from expert doctor

The screenshot shows a web application window titled "Lab Tests Results" with a "Record saved." notification. The window contains a form with the following fields:

- ID: TEST052
- Test type: Height
- Date of the Analysis: 09/23/2017 15:15:29
- Patient: Rahim
- Pathologist: (empty)
- Date requested: 09/23/2017 15:15:29
- Physician: Tutul Bhattachryya

Below the form is a table titled "Lab Test Critearea" with the following data:

Warr.	Exclu	Analyte	Value	Result - Text	Lower Limit	Upper Limit	Units	Remarks
<input type="checkbox"/>	<input type="checkbox"/>	Height	177.0		50.0	500.0	Centimeter	

Figure 13: Patients lab test result from the health system

Discussions

In this paper, we have developed the height and weight sensor module with arduino uno. Our developed module has the capabilities of transferring real time test data of patients to the expert doctor through telemedicine model. In our local market, the price of this combo sensor is 12000-14000 taka which has no data transfer and storage facility. But our developed module costs only 2500 taka with real time data transfer and storage facility.

Health systems of Bangladesh are not connected with each other. As a result, health data of one hospital are not compatible with other health system. Transmission of health data does not follow any international guidelines. In this research, we have used Health Level Seven International (HL7) based health system. This health system is inter-operable with any HL7 certified health system of the world. As a result, patients need not to carry any hard copies of data related to their disease. Doctors get the patient related information through the health system. These arrangements reduce the treatment cost of the patients and better healthcare services can be given through the developed system.

In order to make the real time health monitoring system cost effective, we have used Raspberry Pi based remote client log-in system. This arrangement has reduced the remote telemedicine center setup cost significantly.

We have made a low cost portable telemedicine tool kit in order to collect the vital signs of patients remotely. Major components are arduino uno and e-health sensor shield and the sensors. Our developed tool kit is capable of running with USB power system. This tool kit is small in size and portable. We can extend the sensors to be connected with the tool kit for collecting more vital signs such as ECG, blood pressure, temperature, glucometer, SPO2, airflow of patients in future.

Conclusion

The developed real time health monitoring system offers an improved telemedicine services for the rural remote patients of Bangladesh. This system provides an international standard telemedicine service of patients at low cost. The proposed system was successfully implemented and tested with the patients of Marie Stopes Bangladesh hospital. Due to especially developed hardware's and direct focus on the current problems of telemedicine services, the developed system was highly accepted on both sides, doctors and patients. We have implemented HL7 based health system in this research which is unique among the telemedicine models of Bangladesh. Authors believe that the implementation of the proposed system will advance the healthcare system for the rural people of Bangladesh.

Acknowledgement

Authors would like to thanks to the Information and Communication Technology Division of Ministry of Posts, Telecommunications and Information Technology, Bangladesh for their fellowship of PhD program. Authors would also like to give especial thanks to the officials of Computer and Electronics labs of Jahangirnagar University, Savar, Dhaka, Bangladesh for their assistance to make this research successful.

References

- [1] W. R, H. K, P. NG, and S. RE, "Telehealth in the developing world" *Journal of Health Informatics in Developing Countries*, 2009, Vol. 2(3), pp 1-5.
- [2] M. M. Baig and H. J. Gholamhosseini, "Smart health monitoring systems: an overview of design and modeling", *Journal of Medical Systems*, 2013, Vol. 37(2), pp 1-14.

- [3] C. O. Rolim, F. L. Koch, C. B. Westphall, J. Werner, A. Fracalossi, and G. S. Salvador, In the proceedings of Second International Conference on e-Health, Telemedicine, and Social Medicine as A cloud computing solution for patients data collection in health care institutions, 2010, pp 95-99.
- [4] DGHS, “Health bulletin 2016”.
(<http://www.dghs.gov.bd/index.php/en/publications/health-bulletin/dghs-health-bulletin>, 2016)
- [5] W. H. Organization, “Global health observatory (gho) data”.
(<http://www.who.int/gho/en/>, 2017)
- [6] Deepti and M. Singhroha, “Telemedicine and e-health: Today and tomorrow”, An International Journal of Advanced Computer Technology, 2014, 3(11).
- [7] U. K. Proadhan, M. Z. Rahman, and I. Jahan, In Proceedings of International Conference on Computing, Communication and Automation as A survey on the telemedicine in Bangladesh, 2016, pp 857-861.
- [8] U. K. Proadhan, M. Z. Rahman, and I. Jahan, “A survey on the assessment of the present states and opportunities of telemedicine in Bangladesh”, International Journal of Computer Science and Information Security, 2017, 15.
- [9] U. K. Proadhan, M. Z. Rahman, and I. Jahan, In the Proceedings of International Conference on Advanced Information and Communication Technology as A systematic analysis on the telemedicine services in Bangladesh, 2016, Vol. 1, pp 1-6.
- [10] S. T. A. S, K. Thanuja, N. S. Guptha, and S. Narasimha, , In the Proceedings of International Conference on Computing Technologies and Intelligent Data Engineering as Telemedicine approach for remote patient monitoring system using smart phones with an economical hardware kit, 2016, pp 1- 4.
- [11] I. B. Jafarl, M. Z. I. Shahin, and P. Chakraborty, In the Proceedings of International Conference on Electrical Engineering and Information and Communication Technology as Prospect and implementation of telemedicine centers in South Asian countries, 2015, Vol. 2, pp 1-5.
- [12] M. K. A. Sikder, A. N. Chy, and M. H. Seddiqui, In the Proceedings of International Conference on Informatics, Electronics and Vision as Electronic health record system for human disease prediction and healthcare improvement in Bangladesh, 2013, pp 1-5.

- [13] A. M. Ghosh, D. Halder, and S. A. Hossain, In the Proceedings of International Conference on Informatics, Electronics and Vision as Remote health monitoring system through IoT, 2016, Vol. **5**, pp 921-926.
- [14] R. K. Pathinarunpothi and E. Rangan, “Large scale remote health monitoring in sparsely connected rural regions”, in IEEE 2016 Global Humanitarian Technology Conference, 2016, pp 694-700.
- [15] U. M. Khan, Z. Kabir, and S. A. Hassan, In the Proceedings of International Wireless Communications and Mobile Computing Conference as Wireless health monitoring using passive wifi sensing, 2017, pp 1771-1776.
- [16] N. A. Anoop and T.K.Parani, In the Proceedings of International Conference on Green Engineering and Technologies as A real time efficient and secure patient monitoring based on wireless body area networks, 2016, 1-5.
- [17] J. Joshi, S. Mittal, B. Bridi, R. Kumar, D. S. Kurian, S. Mukherjee, and P. Awasthi, In the Proceedings of International Conference on Information and Communication Technology as Secure and wearable computing in WBANs, 2016, pp 65-70.

